

INTELLISPEC™

Date Code Module Series V

Pressco Technology Inc.

1.0



© 2018 Pressco Technology Inc. All rights reserved.

No part of this manual may be reproduced or transmitted in any form or by any means, electronic or mechanical, including photocopying and recording, for any purpose, without the express written permission of Pressco Technology Inc.

The contents of this manual are furnished for informational use only, are subject to change without notice, and should not be construed as a commitment by Pressco Technology Inc.

Written and designed at:

Pressco Technology Inc. World Headquarters

29200 Aurora Road

Cleveland, OH USA 44139-1847

TEL +1-440-498-2600

FAX +1-440-498-2615

www.pressco.com

Business Hours: Monday - Friday, 8:00am - 5:00pm Eastern Time

Customer Support:

24/ 7 Customer Support (for urgent system help): +1-440-498-2000

e-mail: Schedule a service visit: [*dispatch@pressco.com*](mailto:dispatch@pressco.com) (*mailto:dispatch@pressco.com*)

Request technical support and remote support: [*techsupport@pressco.com*](mailto:techsupport@pressco.com) (*mailto:techsupport@pressco.com*)

Customer Service Fax: +1-440-498-4761

Table of Contents

- Chapter 1 Date Code Module.....5**
 - Inspection Module Adjustments.....7
 - Observe the Part Image7
 - Date Code Module Height Adjustment.....8
 - Date Code Module Camera Adjustments9
 - Date Code Module Lighting Adjustments10
 - Date Code Module - Wiring Diagram12
- Maintenance Frequency13**
 - Surfaces to be cleaned on Date Code Module.....14
 - Cleaning Glass Surfaces.....14
 - Cleaning Plastic Surfaces.....14
 - Cleaning the Vision Processor filter15
 - Cleaning the Cluster Box filters.....16
- Index19**

Chapter 1

Date Code Module

The Date Code inspection module detects the presence of laser-printed date codes on filled bottles. The module uses one camera and one or more custom lighting arrays mounted behind or above the part being inspected (depending on the bottle type and contents).

Date Code inspection determines if the printed characters are present to a sufficient degree based on the software settings, but it is not able to read the characters. This inspection requires that the bottle area where the code is printed be free of water droplets and condensation.

The main components of the date code inspection module are shown below. Note that your system configuration may differ.

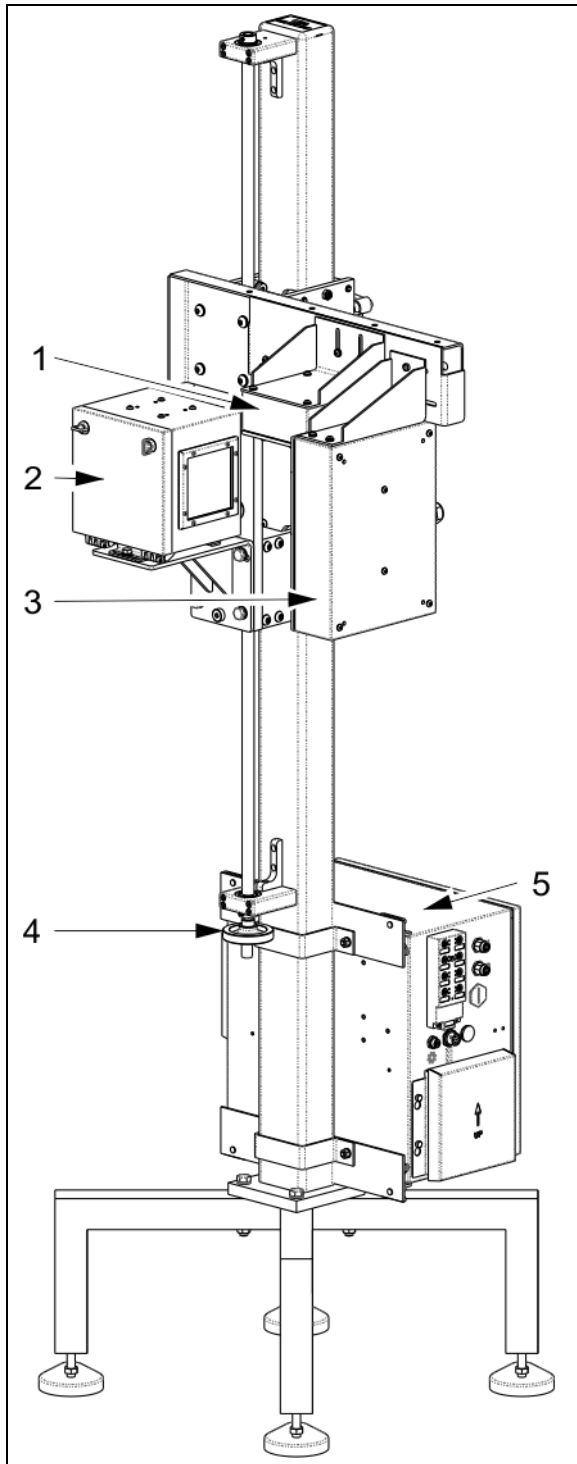

- 1) Light module
- 2) Camera module
- 3) Large light module
- 4) Hand crank to adjust module height
- 5) Cluster box

Inspection Module Adjustments

Inspection module adjustments include the camera position, aperture, and camera focus.

The focus adjustment controls the clarity of the image; the aperture adjustment controls the amount of light admitted by the shutter. Normally the inspection modules do not require further adjustment after initial system setup. Circumstances that might require additional adjustments are camera replacement, strobe replacement, or a substantial change in part size or color.



Danger - The inspection modules are mounted near moving machinery. Use extreme caution to avoid contact with moving machinery when servicing inspection modules as serious personal injury could result. Ensure machinery is in an emergency stop state before servicing inspection modules.

Observe the Part Image

When adjusting the focus, aperture, or height for any inspection module, it is helpful to use Offline Imaging so that you can immediately see the effect of an adjustment on the image quality.



➤ **To use Run in Immediate Mode:**

1. Make sure the lane is offline.



2. Select a sensor , then right-click the button.
3. Select **Offline Imaging** from the menu.
4. Click the **Run** button under Immediate Mode, then run a part through the inspection module.

While the system is in this mode, you will be able to make adjustments to focus, aperture, or camera height.

Date Code Module Height Adjustment

To change the position of the camera and light modules with respect to the conveyor (refer to the illustration below):

❖ *Note: the camera box and light module(s) are mounted as one assembly. They will move together.*

1. Loosen the handles (1) to allow the camera and light module assembly to move.
2. Use the hand crank (2) to move the assembly up or down.
3. When you have moved the assembly into the desired position, tighten the handles (1).

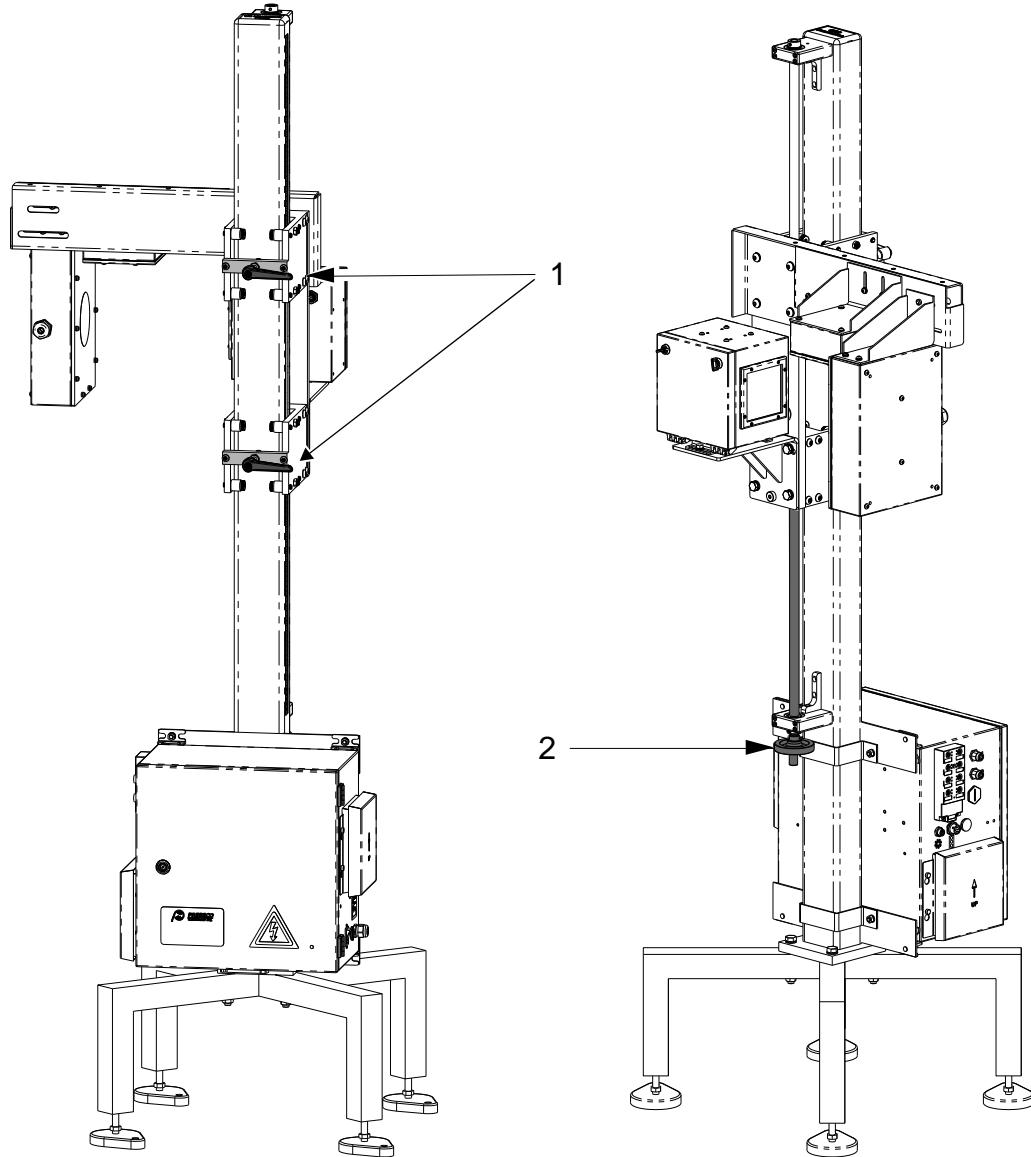

Date Code Module Camera Adjustments



Caution: Electricity is present. Do not use metal screwdrivers or other tools inside the camera box. Do not touch the components, except for the focus and aperture rings on the camera lens.

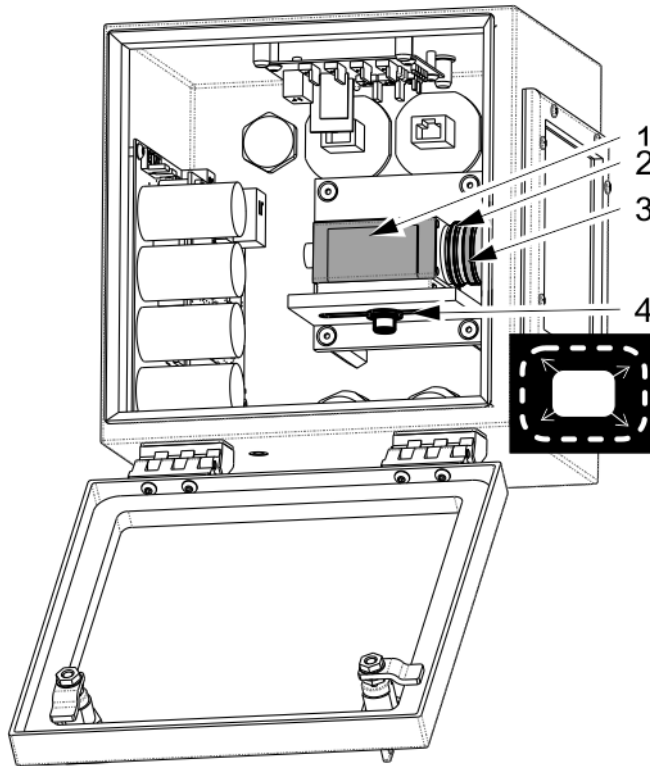

Turn the two latches on the module door to open.

- 1) Camera
- 2 and 3) Focus or aperture adjustment (depending on lens)
- 4) Image size adjustment (NOTE: the camera may be mounted at 90 degrees rotation, so that the adjustment screw is located behind the camera)

Camera Position

❖ *Note: Normally, you do not need to adjust camera position. Adjust only if you are initially installing, or have replaced the inspection module.*

The camera(s) can be adjusted for image size and position. Carefully remove the side panel cover of the inspection module. Adjust camera(s) as necessary while observing image on Intellispec monitor. After making all camera adjustments, replace module cover.

Focus

Look at the part image to observe the adjustments: **Observe the Part Image** (on page 7)

To adjust focus, carefully remove or open the inspection module cover. Turn the focus adjust ring while observing the part image on the monitor. Adjust the focus for the sharpest image. If needed, adjust the aperture, then reinstall the cover.

Aperture

The aperture controls the amount of light that passes through the lens. The programmable light source provides the range of light intensity required for most applications. However, you can manually adjust the aperture if necessary by turning the aperture adjust ring on the camera lens. Reinstall the cover.

Date Code Module Lighting Adjustments

To adjust the lighting, use the software adjustments.

To see the image on the screen:

Observe the Part Image (on page 7)

Adjust lighting through either:

- **Basic adjust lighting** (on page 10), or
- **Advanced adjust lighting** (on page 11)

Most often, you will use Basic Adjust Lighting.

Basic Adjust Lighting

Basic lighting provides most of the lighting adjustments you will use. Lighting must be adjusted while the lane is offline.

To get to this screen: Right-click over a sensor button | Lighting | Basic Adjust Lighting.

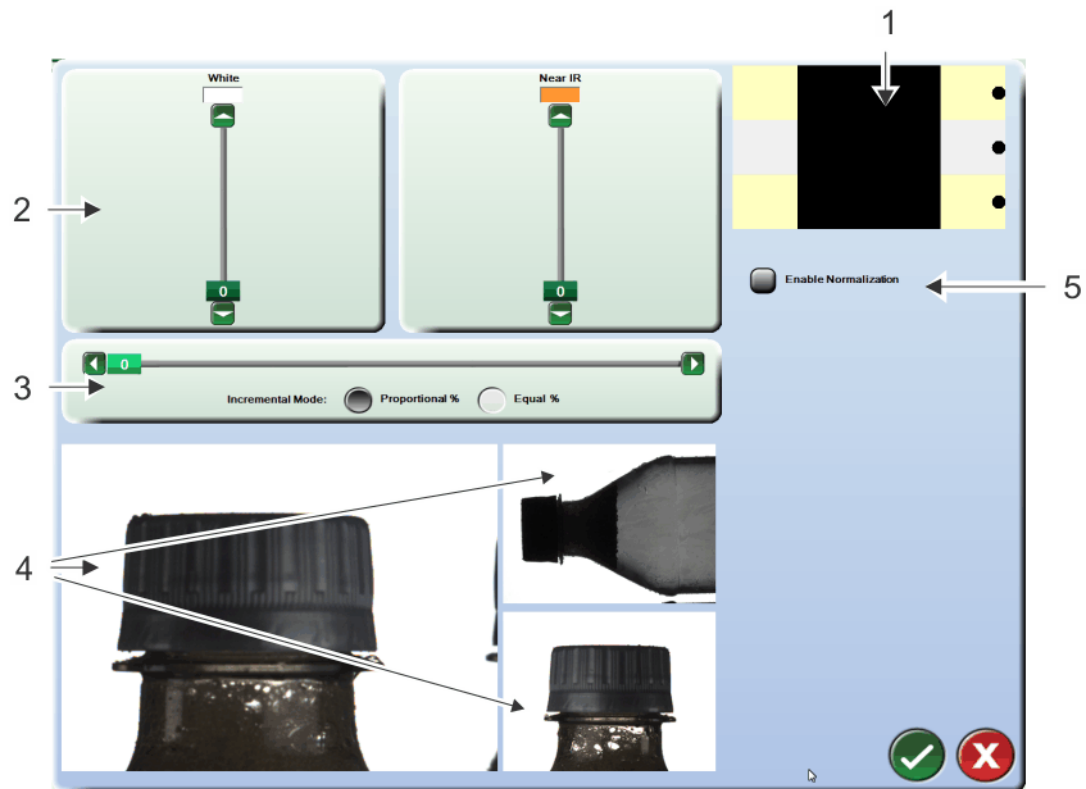

1) - Select a zone to adjust it. You can select a single zone or multiple zones. As lighting is changed, the zone and the button next to it change color.

2) - Separate slider bars for each color (red, green, blue, and infrared) allow individual adjustment.

3) - **Proportional %** - Moving the slider bar adjusts all colors but maintains the current percentage of each color. **Equal % lighting** - Each color is adjusted by the same amount.

4) - Select any image (if applicable to your system) to select the camera to adjust lighting.

5) - **Enable Normalization** - (or Disable Normalization). For most applications leave normalization disabled. If you are modifying an old part program that has normalization enabled, then leave it enabled.

Related topic: **Advanced Adjust Lighting** (on page 11)

Advanced Adjust Lighting

This screen provides additional lighting setup. This is mostly used by Pressco engineers, or for making infrequently performed specialized settings.

❖ *Note: lighting must be adjusted while the lane is offline.*

To get to this screen: Right-click over a sensor button | Lighting | Advanced Adjust Lighting.

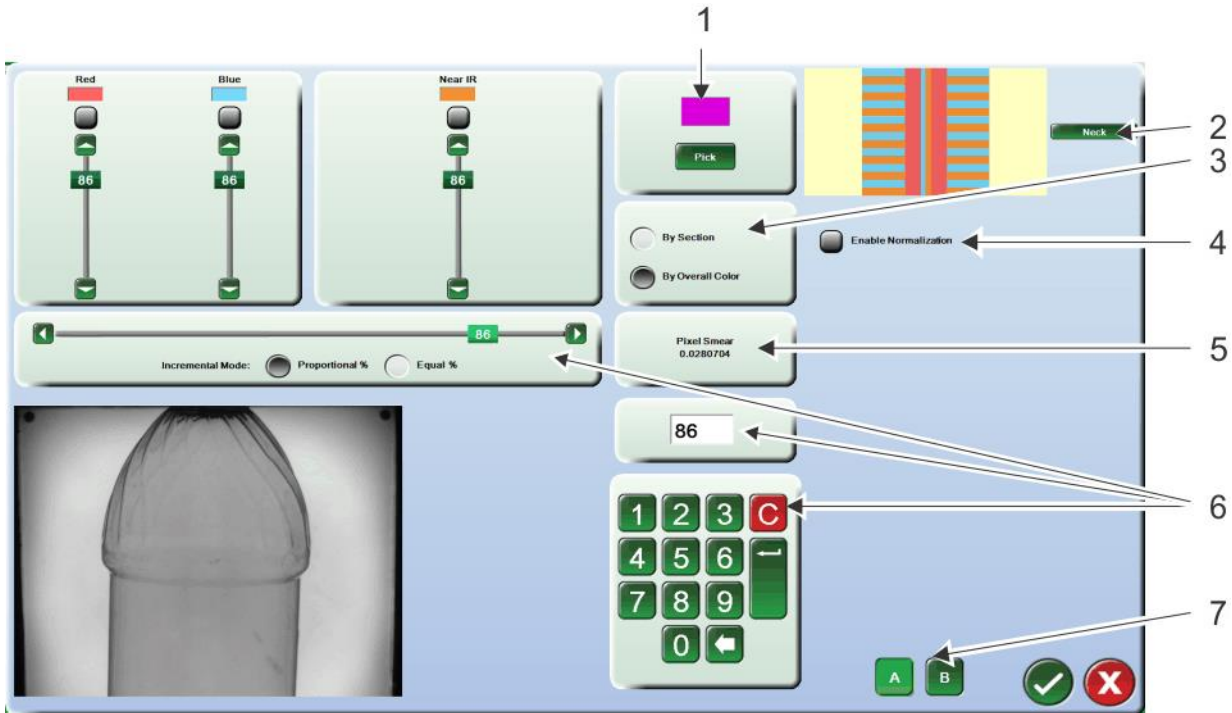

- 1) Opens a color palette and allows you to choose preselected colors.
- 2) If your inspection module has different lighting arrays, click one of the array buttons to adjust lighting by zone. Advanced adjust lighting - zones
- 3) **By Section** - Change lighting by each section. **By Color** - Change lighting for multiple sections at once.
- 4) **Enable Normalization** - (or Disable Normalization). For most applications leave normalization disabled. If you are modifying an old part program that has normalization enabled, then leave it enabled.
- 5) **Pixel Smear** - The Intellispec computes the amount of pixel smear from lighting, image size, and part rate. It should be kept below one.
- 6) **On-screen keypad** - enter the percentage of color. This also moves the percentage slider.
- 7) **A/B buttons** - Set up two different lighting settings for the same part so you can compare.

Date Code Module - Wiring Diagram

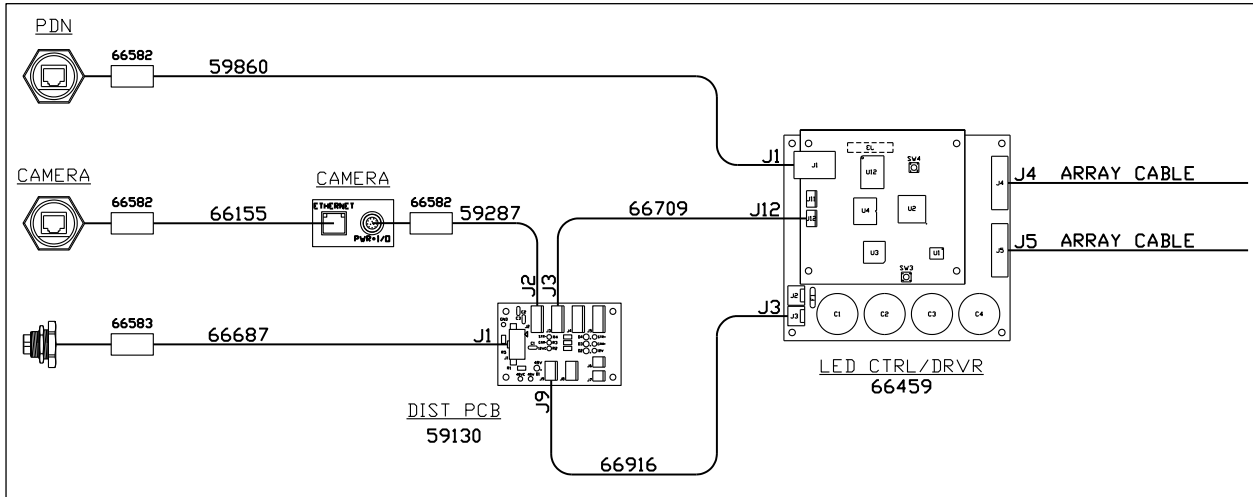

Maintenance Frequency

Follow the guidelines for cleaning and maintenance of the Intellispec system and the inspection modules.

Intellispec Processor Cabinet and General Components			
Item	Description	Once per day or shift	Once per month
Observe Proper inspection	Verify that defective parts are being rejected by inserting a known defective part through inspection	X	
Observe Proper inspection	Verify that no stray parts are stuck in or near the inspection module or reject station	X	
Observe Proper inspection	Verify that no buildup of dirt or contaminants has occurred on inspection module, part detector, or conveyor. Clean if necessary.	X	
Observe Proper inspection	Verify that each camera's image is properly centered, focused, and properly lit. Adjust if necessary.	X	
Vision Processor filter	Rinse in clean water; use mild soap and water solution if oily. Cleaning the Vision Processor filter (on page 15)		X
Cluster Box filters (if applicable)	Rinse in clean water; use mild soap and water solution if oily. Cleaning the Cluster Box filters (on page 16)		X

Inspection Modules PET/ Preform			
Item	Description	Once per week	Once per month
Glass surfaces (see " Cleaning Glass Surfaces " on page 14)	Clean with soft, clean, oil-free cloth dampened with glass cleaning solution.	X	
Plastic surfaces (see " Cleaning Plastic Surfaces " on page 14)	Clean with soft, clean, oil-free cloth dampened with mild soap and water solution.	X	
Part Detect Sensor and Reflector	Clean with soft, clean, oil-free cloth dampened with mild soap and water solution.	X	
Beam Splitter Seal Surface and PSE modules	Clean with soft, clean, oil-free cloth dampened with lens cleaning solution.		X

Surfaces to be cleaned on Date Code Module

Clean the glass and plastic surfaces **once per week**.



Important - Debris and contamination could build up on both the glass and plastic surfaces. This dirt could appear in the inspection windows, causing false rejects of parts, or it could degrade lighting. Clean glass and plastic surfaces often to avoid false rejects.

To maintain proper image quality and system performance, the clear glass and plastic surfaces on the Inspection Modules must be cleaned on a regular basis. Dirt and debris that appear in the image can cause false rejects. An oily film on optical surfaces can cause false rejects or missed defects.

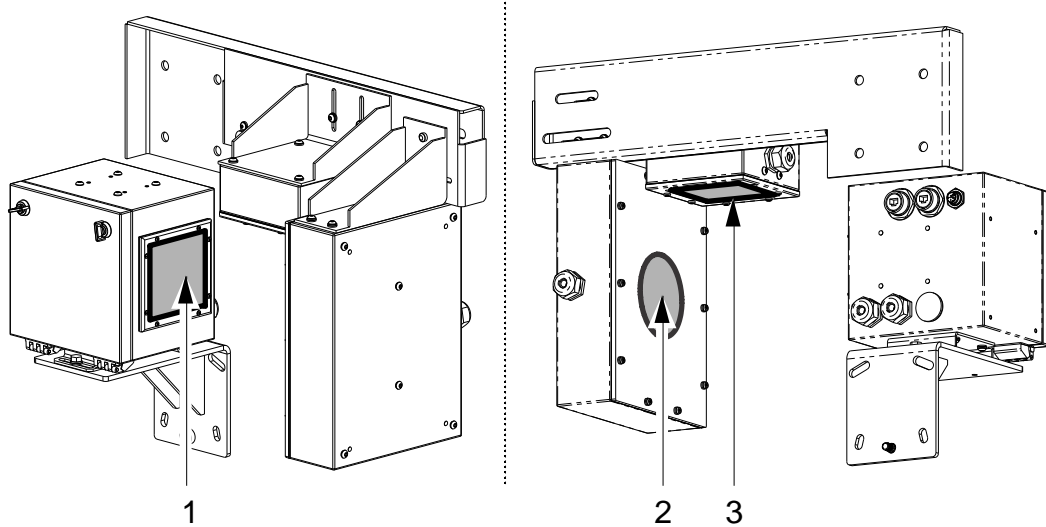

1) Glass window for inspection module - **Cleaning Glass Surfaces** (on page 14)

2 and 3) Plastic windows for lighting modules - **Cleaning Plastic Surfaces** (on page 14)

Cleaning Glass Surfaces

Glass surfaces that may require cleaning are:

- Camera Lens
- Beam Splitter (if present)
- Secondary lens (if present)
- Secondary mirror (if present)

➤ **To clean glass surfaces:**

- Blow off dust with canned, compressed air
- Use a clean non-abrasive cloth dampened with lens cleaning solution
- Use lens tissue and lens cleaning solution on camera lenses
- If surface has compound on it, first clean with alcohol, then with lens cleaning solution

❖ *Note: Cleaning frequency will depend on plant and process conditions.*

Cleaning Plastic Surfaces

Plastic surfaces that may require cleaning are:

- Dome Light Diffuser
- Ring Light Diffuser
- Light Shield (if present)
- Beam Splitter Diffuser (if present)

❖ *Note: Cleaning frequency will depend on plant and process conditions.*

➤ **To clean plastic surfaces:**

Do	Do Not
Use canned compressed air to blow away dust	Do not wipe away dirt as plastic coating may be scratched
Use a clean, non-abrasive cloth dampened with mild soap and water solution. Saturate surface completely to let particles wash away.	Do not use paper towels or paper napkins – these may scratch surfaces
Dry the surface with clean, compressed air	

Cleaning the Vision Processor filter

The filter for the vision processor should be cleaned once a month for best results. The filter is located underneath the user interface cabinet. If the filter has holes or is too dirty to clean, then replace it with Pressco part number 66621.

❖ *Note: You may need to clean the filters weekly depending on plant conditions*

➤ **To clean the filter:**

1. Pull down the front of the grate [item 1] with your fingers.
2. Remove the filter [item 2] and clean it.
 - If the filter contains dry dust and dirt, rinse it in plain water
 - If the filter contains oily dust and dirt, clean it in soapy water, then rinse in clear water
3. Dry the filter completely, then place it back underneath the user interface cabinet.

4. Push the grate closed.

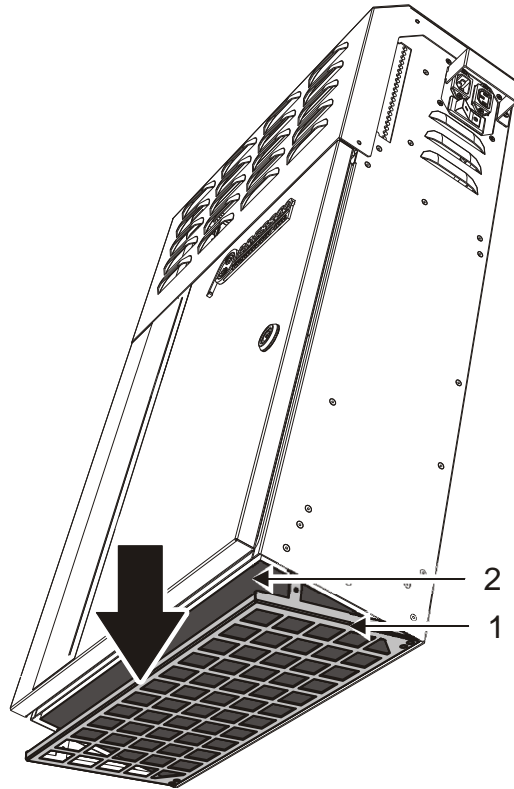

- 1) Grate to hold filter in place
- 2) Part number 66621 - filter for vision processor

Cleaning the Cluster Box filters

Clean the filter on the vents when they get dirty. We recommend that you clean them at least once a month. Remove the covers to access the filters.

- If the filter contains only dry dust and dirt, rinse it in plain water
- If it contains oily dust and dirt, clean it in soapy water

- Dry the filter completely before reinstalling it

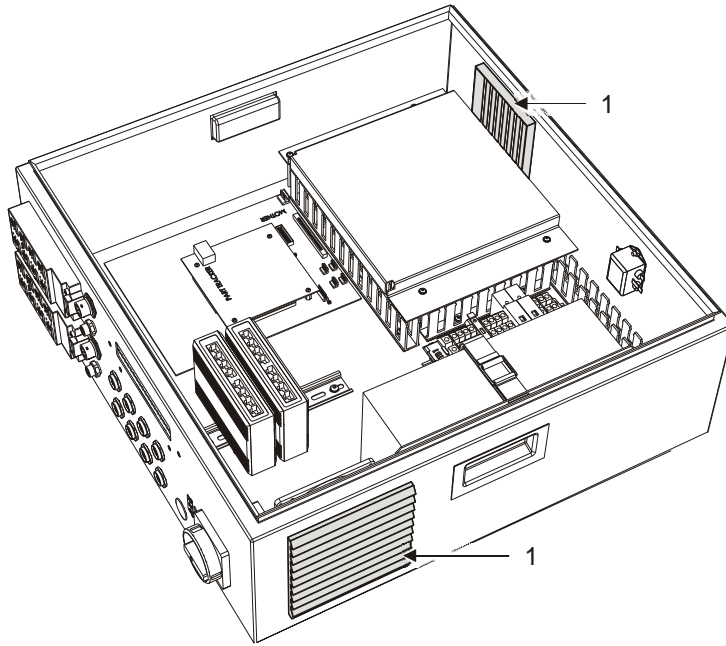

❖ *Note: the illustration shows a Classic cluster box. However, all types of cluster boxes use the same filter replacement.*

To replace a filter, use the part number listed below:

	Part Number	Description
1	65779	Replacement filter element (same part number is used in both locations)

Index

A

ADVANCED ADJUST LIGHTING • 11

B

BASIC ADJUST LIGHTING • 10

C

CLEANING GLASS SURFACES • 14

CLEANING PLASTIC SURFACES • 14

CLEANING THE CLUSTER BOX FILTERS • 16

CLEANING THE VISION PROCESSOR FILTER • 15

D

DATE CODE MODULE • 5

DATE CODE MODULE - WIRING DIAGRAM • 12

DATE CODE MODULE CAMERA ADJUSTMENTS • 9

DATE CODE MODULE HEIGHT ADJUSTMENT • 8

DATE CODE MODULE LIGHTING ADJUSTMENTS • 10

I

INSPECTION MODULE ADJUSTMENTS • 7

M

MAINTENANCE FREQUENCY • 13

O

OBSERVE THE PART IMAGE • 7

S

SURFACES TO BE CLEANED ON DATE CODE MODULE •
14